

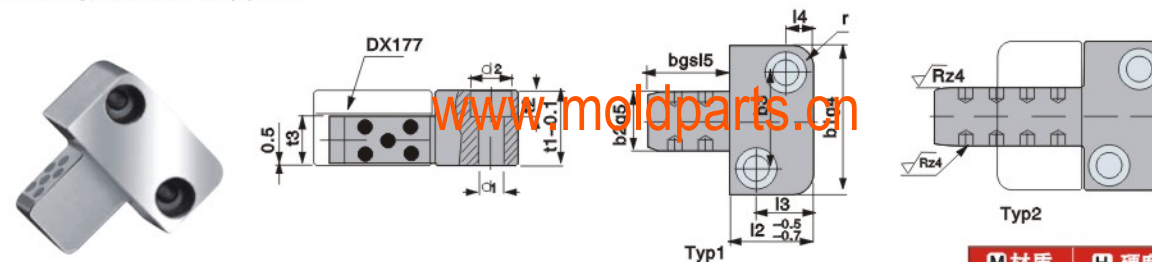

Hasao标准定位滑块Z07



<b>M</b> 材质	<b>H</b> 硬度
Material	Hardness
SKD11+石墨	58-62HRC

订购代码 Catalog No.		尺寸 Size													单价(¥) Price
代号 Type	型号 Model	r	t3	t2	t1	d2	d1	l4	l3	b3	b1	l2	b2	l1	
DX054	Z07/22/16x20	6	11	6.8	20	11	6.6	7	15	26	40	22	16	20	500.00
	Z07/22/16x40				40									500.00	
	Z07/27/20x25				25									700.00	
	Z07/27/20x50				50									700.00	
	Z07/36/25x32	8	14	9	25	15	9	11	35	45	63	46	32	32	700.00
	Z07/36/25x63				63									700.00	
	Z07/46/32x40				40									900.00	
	Z07/46/32x80				80									900.00	
	Z07/56/40x50	10	22	11	36	18	11	15	40	60	85	56	40	50	1100.00
	Z07/56/40x100				100									1100.00	
	Z07/66/50x56				56									1400.00	
	Z07/66/50x112				112									1400.00	

Hasao标准定位滑块Z17

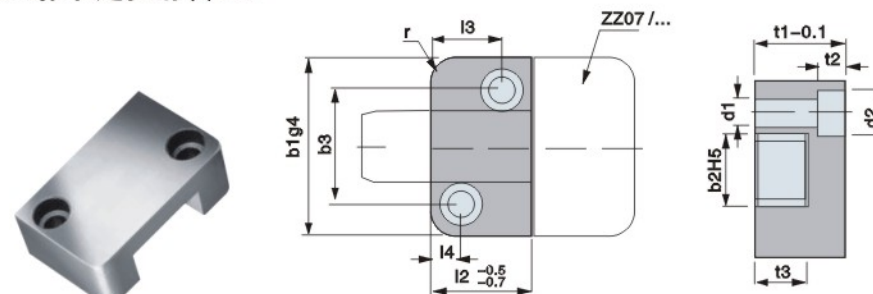

<b>M</b> 材质	<b>H</b> 硬度
Material	Hardness
SKD11	58-62HRC

订购代码 Catalog No.		尺寸 Size													单价(¥) Price
代号 Type	型号 Model	r	t3	t2	t1	d2	d1	l4	l3	b3	b1	l2	b2		
Dx055	Z17/22/16	6	12	6.2	20	10.3	6.3	7	15	26	40	22	16	300.00	
	Z17/27/20				20									350.00	
	Z17/36/25	8	15	9	25	15	9	11	35	45	63	46	32	400.00	
	Z17/46/32				32									500.00	
	Z17/56/40	10	23	11	36	18	11	15	40	60	85	56	40	550.00	
	Z17/66/50				50									600.00	



圆型定位锁/直身定位锁  
Round positioning lock / lock upright positioning

圆型定位锁 Z06

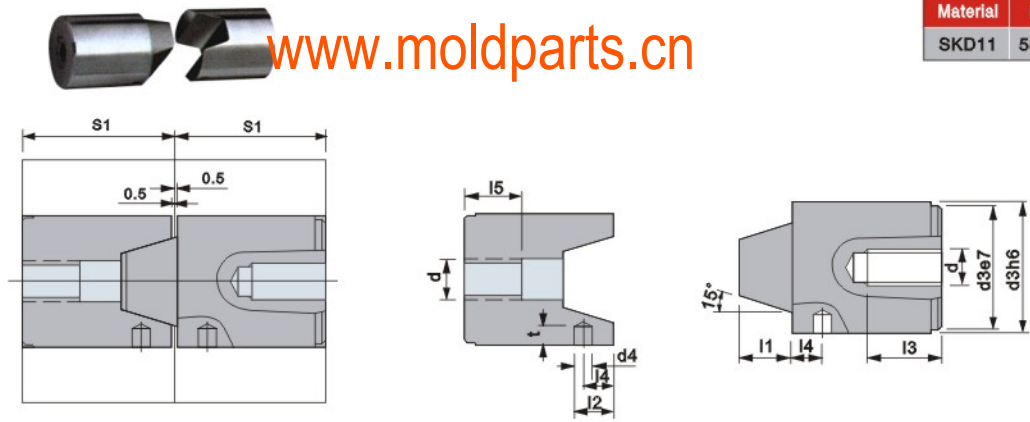

M 材質	H 硬度
Material	Hardness
SKD11	58~62HRC

www.moldparts.cn

订购代码 Catalog No.		尺寸 Size										单价(¥)
代号 Type	型号 Model	t	d4	d	l5	l4	l3	l2	l1	S1	bs	Price
DX056	Z06/30	5	4	M10	16.5	4.5	20	11.5	10.5	36	30	200.00
	Z06/42	7	5	M10	18.5	5.5	20	15.5	14.5	46	42	250.00
	Z06/54	8	6	M12	20.5	7.5	25	18.5	17.5	56	54	300.00
	Z06/80	11	8	M16	25.5	7.5	30	28.5	27.5	76	80	350.00

Hasao标准直径定位锁Z08

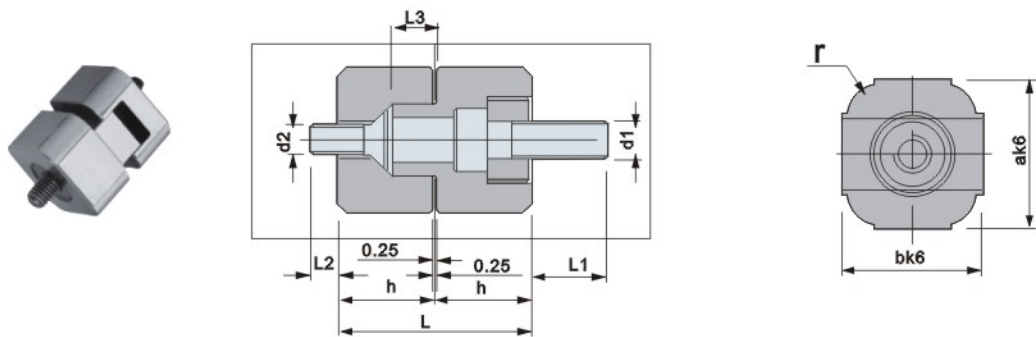

M 材質	H 硬度
Material	Hardness
SKD11	58~62HRC

订购代码 Catalog No.		尺寸 Size										单价(¥)
代号 Type	型号 Model	r	d1	d2	l1	l2	l3	l	h	a	b	Price
DX057	Z08/20x20	4	M5	M4	12	4	3.5	28	14	20	20	500.00
	Z08/25x25	5	M6	M5	13	8	5.5	32	16	25	25	500.00
	Z08/32x32	6	M8	M6	15	12	7.5	36	18	32	32	600.00
	Z08/40x40		M10	M8	17	10	9.5	45	22.5	40	40	700.00

方型定位锁  
Square positioning lock

方型定位锁 YSL... YSLM...

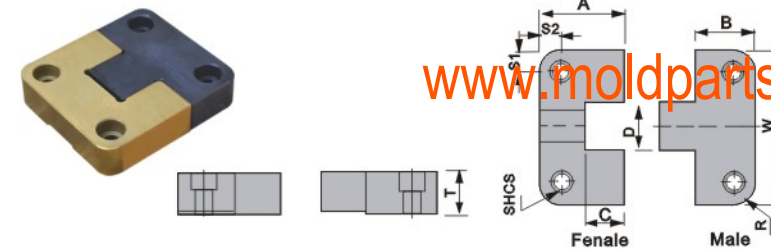

M 材質	H 硬度	H 表面涂层
Material	Hardness	Surface coating
SKD11	58~62HRC	80HRC
H-13	50~56HRC	80HRC

订购代码 Catalog No.		尺寸 Size										单价(¥)
代号 Type	型号 Model	W +0.000 -0.000	T +0.000 -0.002	A +0.000 -0.002	B +0.000 -0.002	C	D .0001/.0002	B +0.000 -0.004	R	S1/S2 ±0.1	内六角螺栓 S.H.C.S	Price
DX058	YSL37×100	1.000	.375	1.125		.53	.500	2.000		.250	#10-32×1/2"	150.00
	YSL50×125	1.250	.490	1.375		.66	.500	2.000	.187	.250	#8-32×5/8"	180.00
	YSL50×150	1.500	.500	.875	.875	.56	.563	1.750		.312	#10-32×5/8"	180.00
	YSL50×200	2.000	.750	1.875		.66	.750	2.250		.375	1/4-20×3/4"	200.00
	YSL50×300	3.000	.750	1.875		1.13	1.250	2.750	.250	.375	1/4-20×3/4"	200.00
	YSL100×400	4.000	1.000	2.375		1.25	1.500	3.750	.500	.500	3/8-16×1"	200.00
	YSL125×500	5.000	1.250	2.875	1.375	1.63	2.000	4.250	.500	.625	1/2-13×1-1/4"	250.00
	SSL150×600	6.000	1.500	2.875	1.375	1.75	2.500	4.250	.500	.625	1/2-13×1-1/2"	300.00

方型定位锁 YTL...

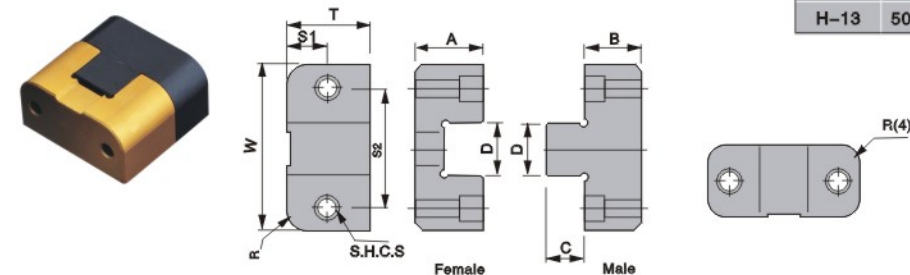

M 材質	H 硬度	H 表面涂层
Material	Hardness	Surface coating
SKD11	58~62HRC	80HRC
H-13	50~56HRC	80HRC

订购代码 Catalog No.		尺寸 Size										单价(¥)
代号 Type	型号 Model	W +0.000 -0.004	T +0.000 -0.002	A +0.000 -0.002	B +0.000 -0.002	C ±.01	D .0001/.0002	S1 ±.01	S2 ±.01	R	内六角螺栓 S.H.C.S	Price
DX059	YTL62×125	1.250	.625	.625	.500	.41	.438	.312	.875	.250	M: #6-32×5/8" F: #6-32×3/4"	250.00
	YTL75×125	1.250	.750	.625	.500	.38	.438	.375	.875	.250	M: #8-32×5/8" F: #8-32×3/4"	300.00
	YTL87×150	1.500	.875	.875	.750	.53	.500	.437	1.000	.250	M: #8-32×7/8" F: #8-32×1"	350.00
	YTL100×150	1.500	1.000	.875	.750	.50	.500	.500	1.000	.250	M: #10-32×1/2" F: #10-32×1"	400.00
	YTL100×200	2.000	1.125	1.125	.750	.66	.750	.500	1.375	.375	M: #10-32×1" F: #10-32×1-1/8"	450.00
	YTL112×200	2.000	1.125	.875	.625	.50	.750	.563	1.375	.375	M: 1/4-20×3/4" F: 1/4-20×1"	500.00
	YTL112×300	3.000	1.500	1.500	.750	.78	1.125	.562	2.250	.500	M: 1/4-20×7/8" F: 1/4-20×1-5/8"	550.00
	YTL150×250	2.500	1.500	1.375	.625	.75	1.000	.750	1.750	.375	M: 1/4-20×3/4" F: 1/4-20×1-1/2"	600.00
	YTL175×300	3.000	1.750	1.250	.875	.75	1.125	.875	2.250	.500	M: 5/16-18×1" F: 5/16-18×1-1/4"	650.00
	YTL200×350	3.500	2.000	1.750	.750	1.00	1.500	1.000	2.500	.500	M: 3/8-16×7/8" F: 3/8-16×2"	700.00



多板定位锁 /  
Multi-board positioning lock

导位固定块  
LOCKING BLOCK SETS-GL TYPE

多板定位锁 YSLX...

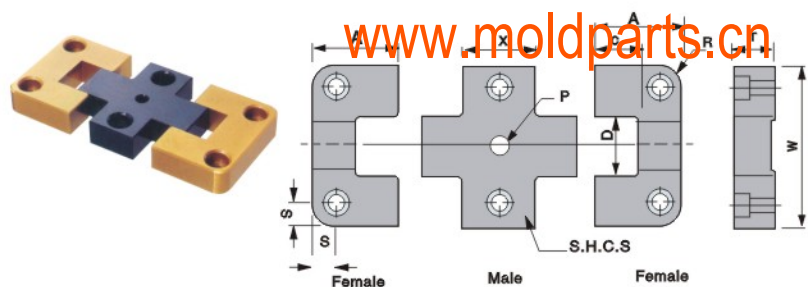

M 材质	H 硬度	H 表面涂层
Material	Hardness	Surface coating
H-13	50~56HRC	80HRC
SKD11	58~62HRC	80HRC

订购代码 Catalog No.		尺寸 Size											单价(¥) Price
代号 Type	型号 Model	W +0.000 -0.004	T +0.000 -0.002	X +0.000 -0.005	A +0.000 -0.002	C ±.01	D .0001/.0002	R	S ±.01	P +0.001 -0.000	内六角螺丝 S.H.C.S		
DX060	YSLX50 x 87	2.000	.500	.875	1.375	.65	.750	.187	.312	.250	#10-32 x 5/8"	400.00	
	YSLX75 x 137	3.000	.750	1.375	1.875	1.12	1.250	.250	.375	.313	1/4-20 x 3/4"	500.00	
	YSLX75 x 187			1.875							3/8-16 x 1"	600.00	
	YSLX100 x 137	4.000	1.000	1.375	2.375		1.500	.500	.500	.375	3/8-16 x 1"	700.00	

多板定位锁 YPLF... YPXM...

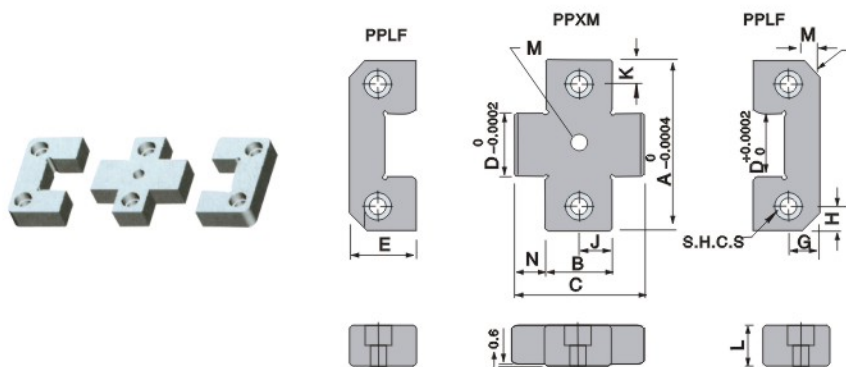

M 材质	H 硬度
Material	Hardness
SKD11	58~62HRC

(英制)

订购代码 Catalog No.		尺寸 Size														单价(¥) Price
代号 Type	型号 Model	A	B	C	D	E	内六角螺丝 S.H.C.S	G	H	J	K	L	M	N	U	
DX061	YPLF-0001 (2REQ' D.)	1.5000	.850	1.470	.5000	.870	1/4-20x3/4	.281	.281	.425	.281	.620	.19	.310	.2500	300.00
	YPXM-2001		1.350	1.970			1/4-20x3/4	.375	.375	.425	.375	.620	.19	.310	.2500	350.00
	YPLF-0002 (2REQ' D.)	2.0000	.850	1.470	.6800	.870	1/4-20x3/4	.375	.375	.425	.375	.620	.19	.310	.2500	400.00
	YPXM-2002		1.350	1.970			1/4-20x3/4	.375	.375	.425	.375	.620	.19	.310	.2500	450.00
	YPLF-0003 (2REQ' D.)	3.0000	.850	1.950	1.0000	1.370	3/8-16x1	.688	.375	.425	.375	.745	.19	.550	.3750	500.00
	YPXM-2003		1.350	2.450			3/8-16x1	.688	.375	.425	.375	.745	.19	.550	.3750	550.00
	YPLF-0004 (2REQ' D.)	4.0000	1.350	1.890	1.3750	1.870	3/8-16x1	.875	.625	.675	.625	.745	.50	.770	.3750	600.00
	YPXM-3004		1.850	3.390			3/8-16x1	.875	.625	.675	.625	.745	.50	.770	.3750	650.00
	YPLF-0005 (2REQ' D.)	5.0000	1.350	2.890	1.7500	1.870	1/2x13x1/4	.875	.750	.675	.750	1.120	.50	.770	.5000	700.00
	YPXM-3005		1.850	3.390			1/2x13x1/4	.875	.750	.675	.750	1.120	.50	.770	.5000	750.00

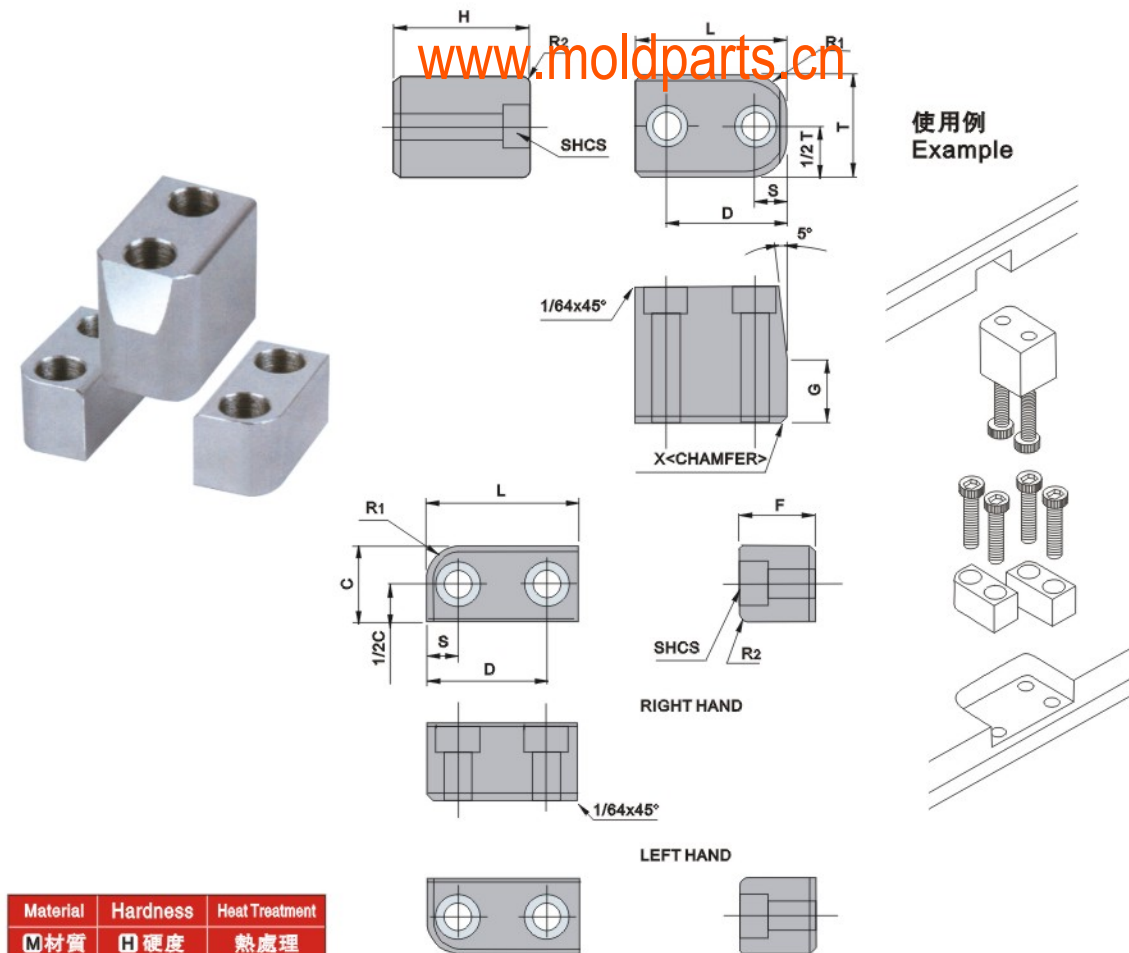

Material	Hardness	Heat Treatment
M 材质	H 硬度	热处理
SKS3	HRC52°~55°	真空处理 Vacuumed
SKD11	HRC58°~62°	

代号 Type	T +0.000 -0.005	L +0.000 -0.010	H +0.000 -0.010	C	S	D	G	F +0.000 -0.005	POCKET (RET)	R1	R2	X	S(SHCS) PELLET SCREWS
DX062-100	0.5	1.0	0.85	0.50	0.25	0.75	0.36	0.50	3/16 or M5	0.22	0.06	0.03	MALE:#10-32x1" FEMALE:#10-32x5/8"
DX062-150	1.0	1.5	1.35	0.75	0.31	1.19	0.61	0.75	1/4 or M6	0.34	0.09	0.06	MALE:1/4-20x1-1/2" FEMALE:1/4-20x7/8"
DX062-200	1.5	2.0	1.73	1.00	0.44	1.56	0.73	1.00	3/8 or M8	0.44	0.09	0.06	MALE:3/8-16x2" FEMALE:3/8-16x1-1/4"
DX062-250	2.0	2.5	2.11	1.25	0.56	1.94	0.86	1.25	1/2 or M12	0.53	0.09	0.09	MALE:1/2-13x2-1/4" FEMALE:1/2-13x1-1/2"

●Order: Type

备注: 画面以外规格可定制  
Remark: Special product is available.

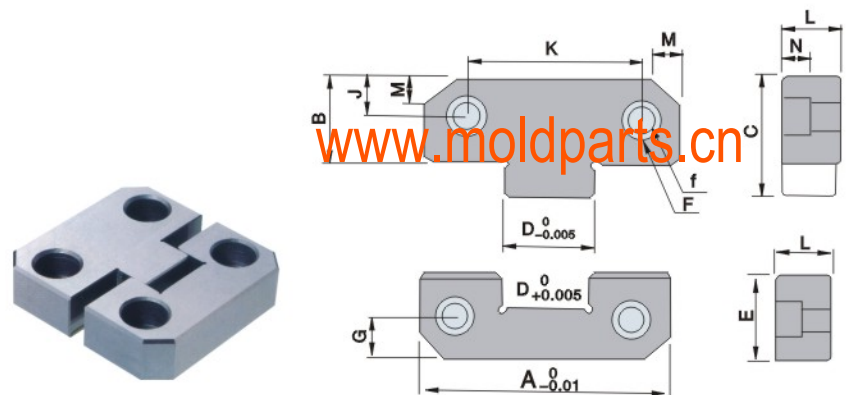

使用例

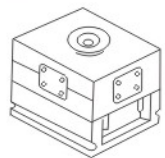

<b>M 材质</b>	<b>H 硬度</b>	<b>热处理</b>
Material	Hardness	Heat Treatment
YK30	HRC56°~60°	真空处理 Vacuumed

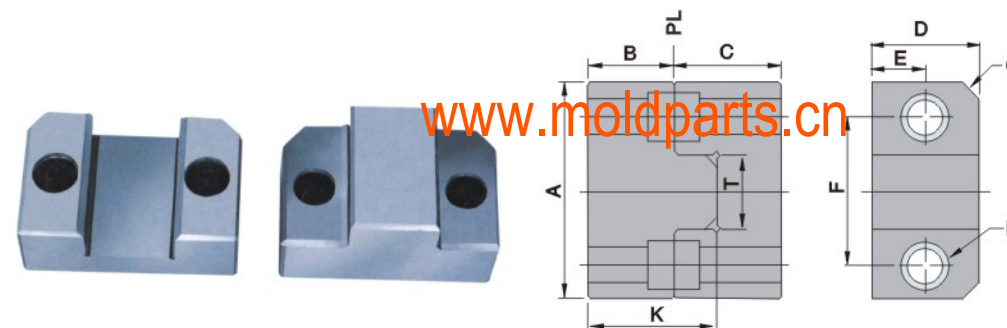

<b>M 材质</b>	<b>H 硬度</b>	<b>热处理</b>
Material	Hardness	Heat Treatment
YK30	HRC56°~60°	真空处理 Vacuumed

定位组件系列

Positioning Component Series

Metric system(mm)

Type	Product code	A	B	C	D	E	F	f	G	J	K	L	M	N	Price 单价 RMB
DX063-1	PL38	38	22	30	12	22	10.5	6.5	7	7	22	13	5	8	210
	PL50	50	21.5	30	17	21.5	10.5	6.5	11	11	34	16	5	8	230
	PL75	75	36	50	25	36	16.5	10.5	18	18	50	19	8	12	325
	PL100	100	45	65	35	45	16.5	10.5	22	22	70	19	10	12	420
	PL125	125	45	65	45	45	16.5	10.5	22	22	84	25	10	12	500

Inch

订购代码 代号 Type	Catalog No. 型号 Model	A	B	C	D	E	F	f	G	J	K	L	M	N	Price 单价 RMB
DX063-2	PL1.5	1.5	0.87	1.18	0.50	0.87	0.433	0.276	0.281	0.437	0.938	0.620	0.19	0.3	210
	PL2.0	2.0	0.87	1.18	0.68	0.87	0.433	0.276	0.375	0.437	1.250	0.620	0.19	0.3	230
	PL3.0	3.0	1.36	1.91	1.00	1.37	0.590	0.413	0.688	0.688	2.250	0.745	0.38	0.45	325
	PL4.0	4.0	1.87	2.64	1.375	1.87	0.590	0.413	0.875	0.875	2.750	0.745	0.50	0.45	420
	PL5.0	5.0	1.87	2.64	1.75	1.87	0.788	0.555	0.875	0.875	3.500	1.120	0.50	0.6	500

备注：圖面以外規格可定制  
Remark:Special product is available.

定位组件系列

Positioning Component Series

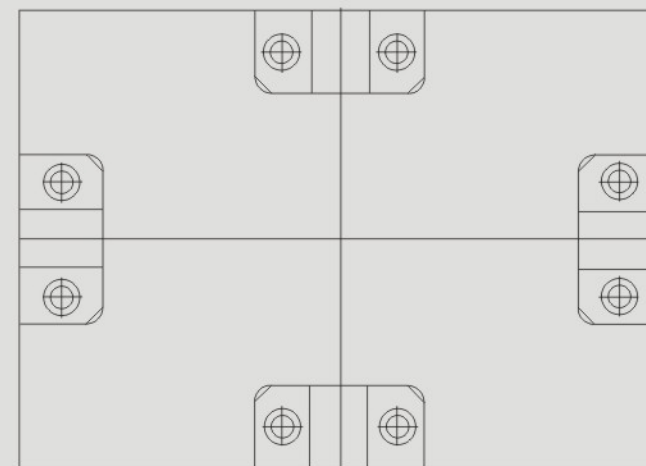

特性說明/Speciality:

- 有效解决侧装式0°定位块槽加工困难的问题。尤其是對大型模胚更具方便性。
  - 用于塑件品質，尺寸精度要求特高的塑膠模具。
  - 材質：SK3(HRC48°~50°)
1. Can solve the 0° locking block sets'slot processing problem effectively.
  2. Apply to plastic mold which has very high demand about plastic product's quality and the tolerance of specification.
  3. Material: SK3(HRC48°~50°)

订购代码 代号 Type	Catalog No. 型号 Model	A	B	C	D	E	F	G	H	K	T	Price 单价 RMB
DX064	LM50	50	20	25	25	12.5	34	C5	M6	30	17	400
	LM75	75	25	30	50	25	52	C8	M8	40	30	480

备注：圖面以外規格可定制  
Remark:Special product is available.



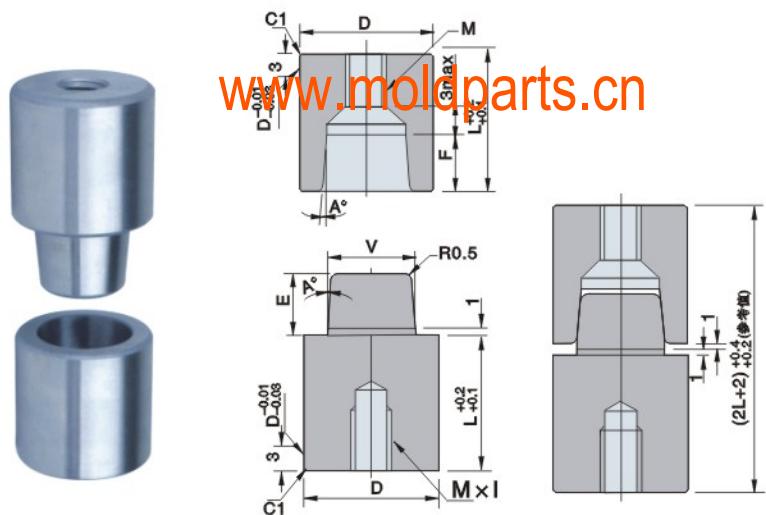

<b>M 材质</b>	<b>H 硬度</b>	<b>热处理</b>
Material	Hardness	Heat Treatment
SUJ2	HRC60° ± 2°	高周波 High Frequency

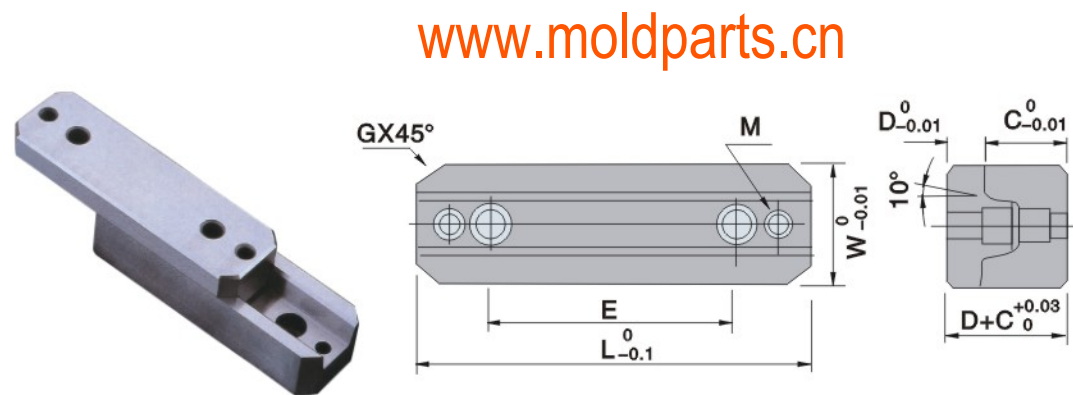

<b>M 材质</b>	<b>H 硬度</b>	<b>热处理</b>
Material	Hardness	Heat Treatment
YK30	HRC56° ~60°	真空处理 Vacuumed

定位组件系列

Positioning Component Series

定位组件系列

Positioning Component Series

订购代码 Catalog No.			A°	L	V	E	F	MXI	单价(¥) Price
代号 Type	D	公差 Tolerance							
DX065	13	+0.012 +0.001	5	14	8.5	6	5	M4X10	182
	16			14	10	6	5	M5X10	182
	20	+0.015 +0.002		19	13	9	8	M6X12	200
	25			24	16	12	11	M8X16	236
	30			29	20	15	14	M10X20	273
	32			29	20	15	14	M10X20	
	35	+0.018 +0.002		34	24	18	17	M12X24	
	42			39	30	24	23	M12X24	

备注：圖面以外規格可定制  
Remark: Special product is available.

Metric system(mm)

订购代码 Catalog No.		W	L	C	D	E	G	M	单价(¥) Price
代号 Type	型号 Model								
DX066-1	KY50	25	50	17.5	8	36	5	M5	185
	KY100	30	100	22	10	60	5	M6	280
	KY150	40	150	25	13	100	5	M8	370

Inch

订购代码 Catalog No.		W	L	C	D	E	G	M	单价(¥) Price
代号 Type	型号 Model								
DX066-2	KY2.0	1.00	1.98	0.69	0.312	1.4173	0.2	3/16"-24	185
	KY4.0	1.25	3.98	0.87	0.375	2.5	0.2	1/4"-20	280
	KY6.0	1.500	5.98	1.00	0.500	4.0	0.2	5/16"-18	370

备注：圖面以外規格可定制  
Remark: Special product is available.